

AUDIO INPUT CONTROL SYSTEM



CONTROL SYSTEM 3-INPUT SWITCH  
INSTALLATION INSTRUCTIONS



CSS-3I



Dear customer,

Congratulations on your purchase of a Bazooka Audio Input Control System. At Bazooka, we are fanatics about accurate music reproduction. Your selection of our products for your sound system indicates that quality sound is also important to you too. At SAS, we take great pride in manufacturing revolutionary audio products, and through the years of engineering expertise, hand craftsmanship and critical testing procedures, we have created this high-performance input switcher. We hope that you will take as much pride in owning and using one of these high-quality audio products as we do designing and manufacturing them.

When properly installed and operated, your Bazooka Audio Input Control System will give you years of clean uninterrupted sound reproduction. Therefore, we urge you to take a few minutes to carefully read through this manual. It will explain all of the features of your amplifier and help insure trouble free installation.

Sound can be deceiving. Over time your hearing comfort level adapts to higher volumes of sound. What may have sounded normal can actually be too loud and harmful to your hearing. Guard against this by setting your equipment at a safe level before your hearing adapts.

To establish a “safe level”,

- Start with your volume control at a low setting.
- Slowly increase the volume control until you can hear comfortably, clearly and without distortion.
- Once you have established a comfortable “sound level”, make a note of this position and do not go above this setting

Taking a minute to do this will help prevent your hearing from being damaged and allow you to enjoy listening to music throughout your lifetime.

# ***SAFETY PRECAUTIONS***

## ***Fuse amplifiers power wire at the battery.***

Be sure to fuse the power wire within 6" of the vehicles battery. This will protect the vehicle and CSS-3I in case of a short circuit between the CSS-3I and battery.

## ***Use high grade wire connectors.***

To ensure maximum power transfer and secure safe connections, it is recommended to use high grade barrier spades (for connection at amplifier if applicable) and terminal rings (for connection at battery).

## ***Do not run any wires underneath vehicle.***

Exposed wires have a chance of being cut or damaged. It is best to run all wires through the vehicle under the carpet and/or side panels. This lends to a cleaner installation and less risk of damage.

## ***Use caution when mounting the CSS-3I.***

Remember there are many electrical wires, gas lines, vacuum lines, brake lines as well as a gas tank in the automobile. Make sure you know where they are when mounting the amplifier to avoid puncturing lines, shorting wires or drilling holes in the gas tank.

## ***Run signal wires away from electrical wires.***

To avoid possibility of induced noise from the vehicles electrical system (i.e. popping noises or engine noise), run wires away from the vehicles electrical wiring.

## ***Make all ground wires as short as possible and at the same point.***

In order to reduce the chance of ground loops (i.e. engine noise), make the grounding wire as short as possible to reduce the wire's resistance. Also, when using multiple components, make sure all units are grounded at the same point.

## ***Avoid sharp edges when running the wires.***

To avoid the possibility of power, signal or speaker shorts, be careful not to allow the CSS-3I wires to come in contact with sharp edges. Use a grommet to protect the wire when running through the fire wall.

# ***FEATURES AND BENEFITS***

## ***Multiple Source Inputs***

The CSS-3I's allows for two low level inputs (RCA's) and one Stereo 3.5mm stereo input jack (MP3 or iPod). This gives the flexibility to choose what source input you wish to play through your amplifier.

## ***Source Thru-puts***

We have included source thru-puts for the inputs A & B. This allows you to pass the same source signal to another CCS-3I or additional amplifiers in the system.

## ***Remote Turn-on***

Automatically turns the CSS-3I on when connected to the head unit's remote output. The CSS-3I will turn on and off with the head unit along with the amplifier attached to the CSS-3I.

## ***CSR Input Jack***

A remote input jack has been provided for connection with optional CSR-W or CSR-I Power, Source and Volume Control. The CSR's allow independent control of source inputs and the volume of the amplifier(s) connected to the CSS-3I.

## ***Adjustable Level Control for A & B Level Inputs***

Independent level matching between each input source and the power amplifier. This allows you to adjust each source input to optimize the overall level to the connected amplifier.

## ***MOUNTING LOCATION***

Before you start the installation, it will be necessary to find a mounting location for the unit. Find a location in which the CSS-3I will receive adequate ventilation in order to dissipate the heat it develops during operation. Do not mount in the engine compartment.

Select the location in which you wish to mount the CSS-3I. Use caution when mounting the CSS-3I, there are many wires, gas lines, vacuum lines, brake lines as well as a gas tank in the automobile. Make sure you know where they are when mounting the unit to avoid puncturing lines, shorting wires or drilling holes in the gas tank. Once you are ready, use a pencil to mark the mounting holes in the bottom panel. After you have marked the locations of the holes move CSS-3I out of the way and drill small starter holes to make the tapping screws easier to install. Use provided screws to tighten down the CSS-3I.

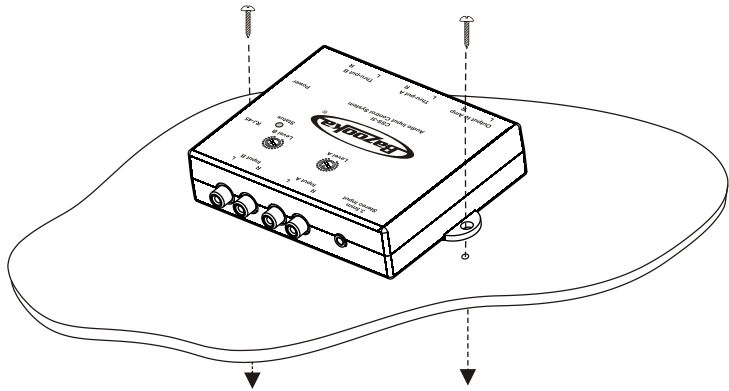

# POWER CONNECTIONS

**IMPORTANT!** Before making any connections, disconnect the vehicles battery until the installation is completed to avoid possible damage to the electrical system.

The Power button on the CSR-W or CSR-I turns any amplifier connected to the Orange wire "ON" or "OFF". Please note that the CSS-3I itself must be powered "ON" from the radio as explained below.

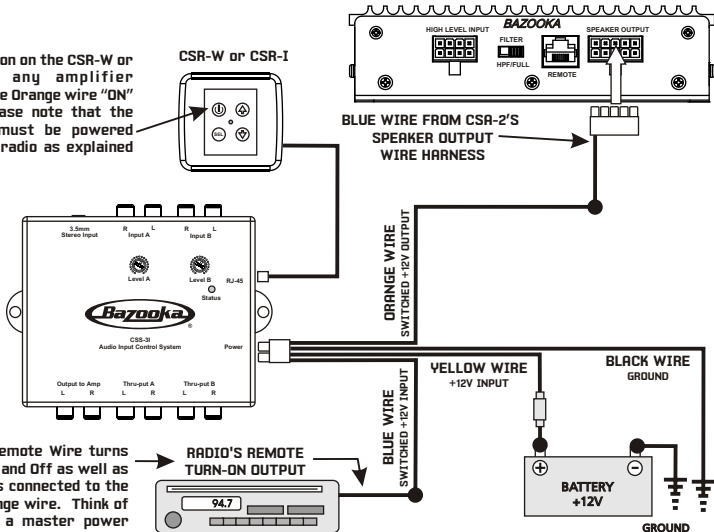

The Radio's Remote Wire turns the CSS-3I On and Off as well as any amplifiers connected to the switched orange wire. Think of the Radio as a master power switch for the entire system.

# SIGNAL CONNECTIONS AND ADJUSTMENTS USING THE CSR-W

To make these connections, we recommend high quality RCA cables, which are available at your local Bazooka retailer. Run signal wires away from electrical wires to avoid possibility of induced noise from the vehicles electrical system (i.e. popping noises or engine noise).

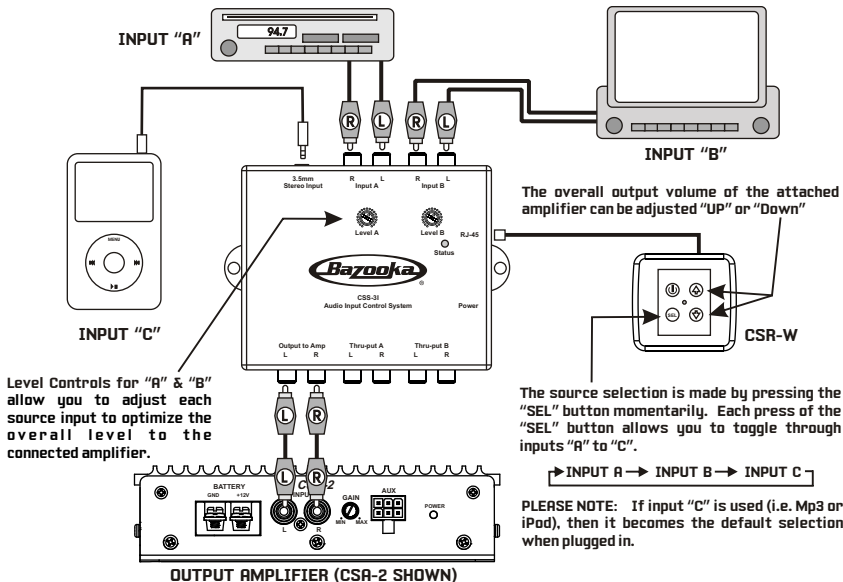



## SIGNAL CONNECTIONS AND ADJUSTMENTS USING THE CSR-I

To make these connections, we recommend high quality RCA cables, which are available at your local Bazooka retailer. Run signal wires away from electrical wires to avoid possibility of induced noise from the vehicles electrical system (i.e. popping noises or engine noise).

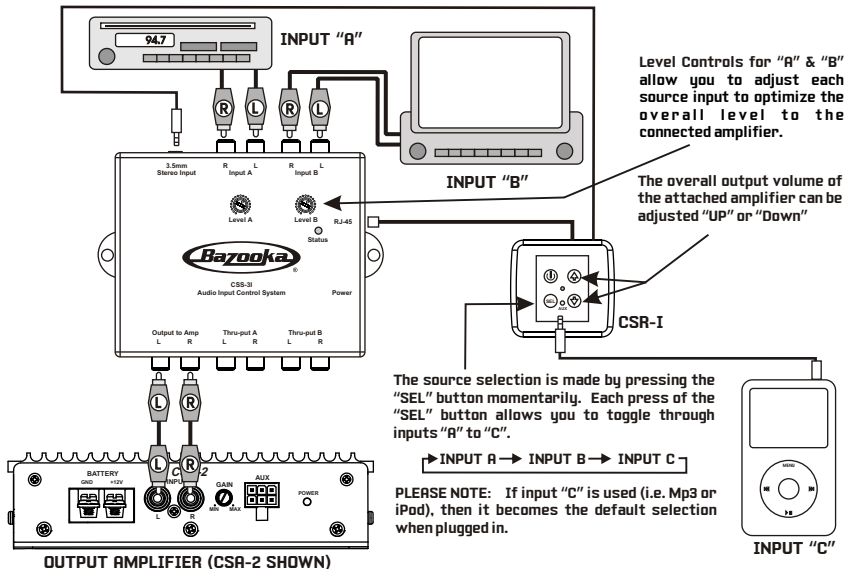

## USING CSS-3I FOR MULTIPLE ROOM APPLICATIONS

The following example shows how multiple CSS-3I's can be connected to share one input source. The CD Player (Input A) signal is passed to the second CSS-3I so that when "Input A" is selected, the CD player can be played through the system in the second room.

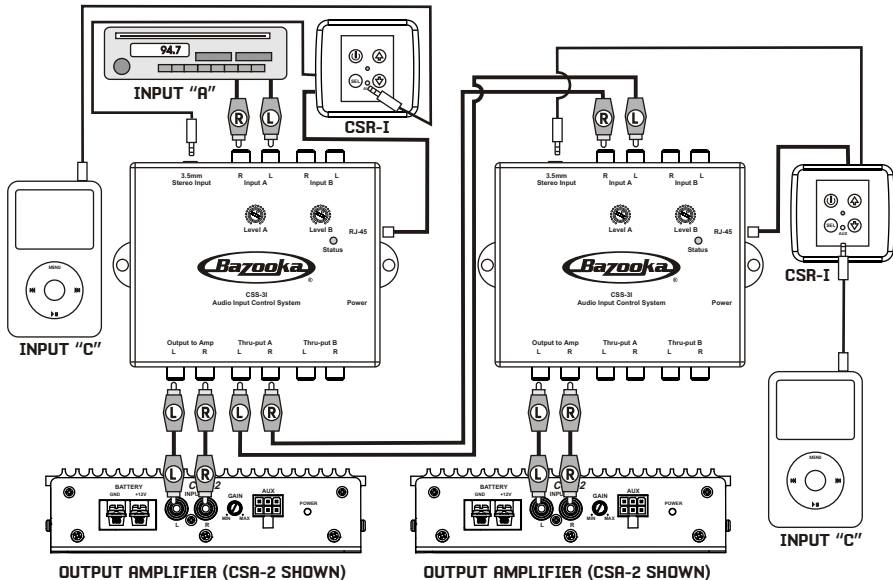

# ***TROUBLE SHOOTING THE SYSTEM***

We have put together this trouble-shooting guide if you experience problems after installing the CSS-3I. Please keep in mind that the majority of problems incurred are caused by improper installation and not the equipment itself. In addition, there are many components in the system that could cause various signal problems such as inducted electrical noise and engine noise.

Before you can properly address the problem, you must first find the component that is causing the problem. This will take patience and a process of elimination.

LOOK FOR....	SOLUTION
<b>No Output</b>	
Blown fuse	Replace
Bad RCA Cable(s)	Replace
+12V at power wire	Check connection
+12V at remote wire	Check connection
Grounding point clean and tight	Check for ground w/meter
Head Unit's fader not in center position	Set to center position
<b>Low Output</b>	
Check level adjustments	Re-adjust
Bad RCA cable(s)	Replace
Improper level setting	Re-adjust
<b>Engine Noise</b>	
Grounding points are clean and tight	Check for ground w/meter
Ground all components at same point	Ground at same point
Try different grounding point	Change for better ground
Bad RCA cable(s)	Replace
Use High Quality shielded RCA cables	Rejects inducted noise
Low Vehicle charging system and/or battery	Fix and/or replace
<b>Music Stops Playing (Possible Amplifier Problem)</b>	
Speaker short	Check speakers connection for short circuit
Speaker grounding out	Make sure speaker wires do not touch ground
Impedance too low	Check speaker impedance (Min 2 ohm Stereo)
Overheating	Check mounting location for Adequate air Circulation Speaker impedance too low

# ***SPECIFICATIONS***

CSS-3I

<b>Inputs:</b>	
Low Level (RCA).....	2 Pairs
3.5mm Jack .....	1 Stereo
<b>Outputs:</b>	
Amplifier .....	1 Pair
Thru-put "A" .....	1 Pair
Thru-put "B" .....	1 Pair
Frequency Response .....	10Hz-100KHz
S/N Ratio .....	>77dB
THD (Thru-put A & B).....	0.001%
THD (Output to Amplifier).....	0.02%
Input Jack for CSR Connection.....	RJ-45
Battery Voltage Range .....	9.5VDC-16VDC
Fuse .....	2A x1

Due to continuing product improvement, specifications subject to change without notice.





## ***LIMITED WARRANTY***

Southern Audio Services, Inc., warrants all products to be free from defects in material and workmanship for a period of one (1) year from the date of purchase. In the event the product is not as warranted, SAS' sole obligation shall be to repair or replace the defective product at SAS' option: SAS limits its obligation under any implied warranties under state laws to a period not to exceed the limited warranty period. SAS and its authorized BAZOOKA® dealers specifically disclaim liability for any incidental or consequential damages. Some states do not allow limitations on how long an implied warranty lasts, and some states do not allow the exclusion or limitation of incidental or consequential damages, so the above limitation or exclusions may not apply to you. This warranty gives you specific legal rights, and you may have other rights, which vary from state to state.

**What is covered:** This warranty covers all defects in materials or workmanship (parts and labor) in the product.

**What is not covered:** This warranty does not cover the following:

1. Damages occurring during shipment of the product to SAS for repair (Claims must be presented to the carrier).
2. Damages caused by accident, abuse, negligence, misuse or improper Operation or installation.
3. Damages caused by an act of God, including without limitation, fire, flood Storm or other acts of nature.
4. Any product, which has a serial number, defaced, altered, modified, or removed.
5. Any product that has been altered or modified without SAS' consent.



### How to obtain warranty services:

1. You are responsible for delivery of the product to an authorized BAZOOKA® dealer or contact SAS at 1-800-THE-TUBE for a Return Authorization number. The Return Authorization number must be clearly written on the outside of the box. Freight must be prepaid to SAS. Warranty replacement parts will be returned freight prepaid. The entire enclosure may be returned for warranty service, but return will be freight collect.
2. You must provide proof of the date of purchase of the product. If proof of purchase is not provided, original date of manufacture will be used to determine warranty period.
3. You must package the product securely to avoid damage during shipment.
4. After acquiring a Return Authorization number, ship to the address below. Please complete this section and retain for your records.

Model(s) purchased \_\_\_\_\_

Serial number(s) \_\_\_\_\_

Date Purchased \_\_\_\_\_

Dealer's name \_\_\_\_\_







**If you have any questions contact the Bazooka Mobile Audio tech dept. at:**

**Phone: 225-272-7135 Fax: 225-272-9844**

**Email - [tech@bazooka.com](mailto:tech@bazooka.com) Website - [www.bazooka.com](http://www.bazooka.com)**



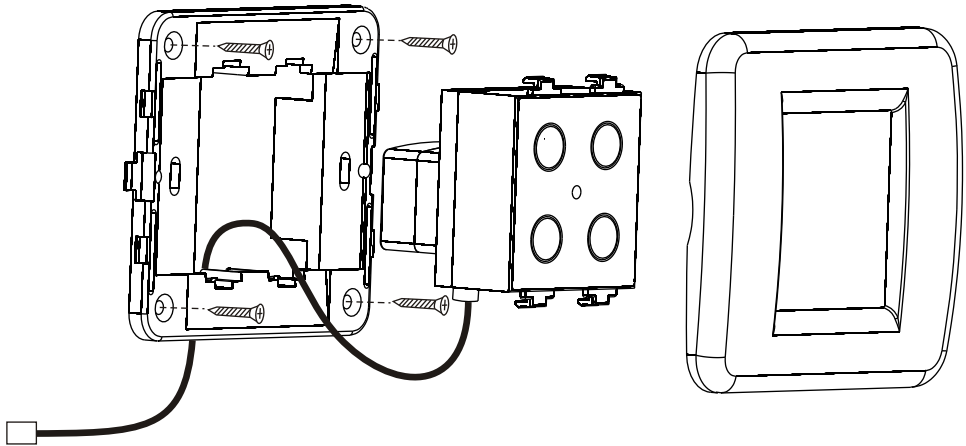

AUDIO INPUT CONTROL SYSTEM



CONTROL SYSTEM REMOTE  
INSTALLATION INSTRUCTIONS



CSR-W / CSR-I

If you have any questions contact the  
 Bazooka Mobile Audio tech dept. at:  
 Phone: 225-272-7135 Fax: 225-272-9844  
 Email - tech@bazooka.com Website - www.bazooka.com



## Waterproof & Interior Remote Sequence of Operation

Depressing the SEL button toggles A/B/C ("C" being the 3.5 input jack.)

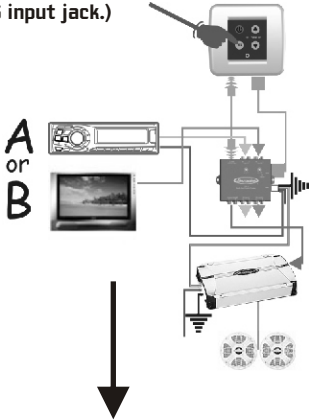

Connecting the 3.5 jack automatically switch's the source to "C"

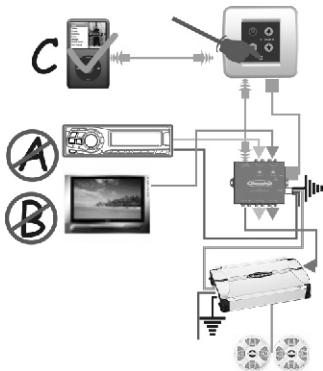

Depressing the SEL button toggles the source to "A"

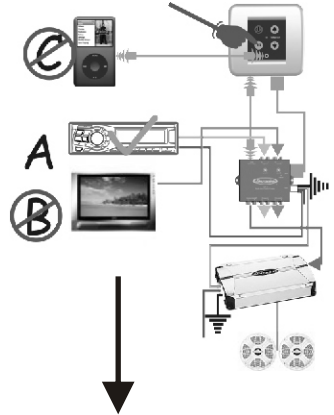

Again depressing the SEL button toggles the source to "B" and depressing it a third time back to "C"

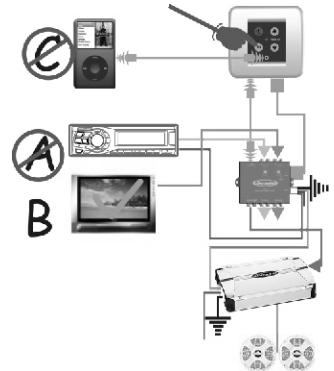

AUDIO INPUT CONTROL SYSTEM



2 CHANNEL 100 WATT AMPLIFIER  
INSTALLATION INSTRUCTIONS

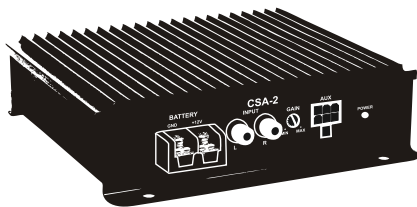

CSA-2



Dear customer,

Congratulations on your purchase of a Bazooka high-performance amplifier. At Bazooka, we are fanatics about accurate music reproduction. Your selection of our products for your sound system indicates that quality sound is also important to you too. At SAS, we take great pride in manufacturing revolutionary audio products, and through the years of engineering expertise, hand craftsmanship and critical testing procedures, we have created this high-performance series of amplifiers. We hope that you will take as much pride in owning and using one of these high-quality audio products as we do designing and manufacturing them.

When properly installed and operated, your Bazooka CSA amplifier will give you years of clean uninterrupted sound reproduction. Therefore, we urge you to take a few minutes to carefully read through this manual. It will explain all of the features of your amplifier and help insure trouble free installation.

Sound can be deceiving. Over time your hearing comfort level adapts to higher volumes of sound. What may have sounded normal can actually be too loud and harmful to your hearing. Guard against this by setting your equipment at a safe level before your hearing adapts.

To establish a "safe level",

- Start with your volume control at a low setting.
- Slowly increase the volume control until you can hear comfortably, clearly and without distortion.
- Once you have established a comfortable "sound level", make a note of this position and do not go above this setting

Taking a minute to do this will help prevent your hearing from being damaged and allow you to enjoy listening to music throughout your lifetime.

# ***SAFETY PRECAUTIONS***

## ***Fuse amplifiers power wire at the battery.***

Be sure to fuse the power wire within 6" of the vehicles battery. This will protect the vehicle and amplifier in case of a short circuit between the power amplifier and battery.

## ***Use high grade wire connectors.***

To ensure maximum power transfer and secure safe connections, it is recommended to use high grade barrier spades (for connection at amplifier if applicable) and terminal rings (for connection at battery).

## ***Do not run any wires underneath vehicle.***

Exposed wires have a chance of being cut or damaged. It is best to run all wires through the vehicle under the carpet and/or side panels. This lends to a cleaner installation and less risk of damage.

## ***Use caution when mounting amplifier.***

Remember there are many electrical wires, gas lines, vacuum lines, brake lines as well as a gas tank in the automobile. Make sure you know where they are when mounting the amplifier to avoid puncturing lines, shorting wires or drilling holes in the gas tank.

## ***Run signal wires away from electrical wires.***

To avoid possibility of induced noise from the vehicles electrical system (i.e. popping noises or engine noise), run wires away from the vehicles electrical wiring.

## ***Make all ground wires as short as possible and at the same point.***

In order to reduce the chance of ground loops (i.e. engine noise), make the grounding wire as short as possible to reduce the wire's resistance. Also, when using multiple components, make sure all units are grounded at the same point.

## ***Avoid sharp edges when running the wires.***

To avoid the possibility of power, signal or speaker shorts, be careful not to allow the amplifiers wires to come in contact with sharp edges. Use a grommet to protect the wire when running through the fire wall.

# ***FEATURES AND BENEFITS***

## ***Thermal Protection***

To protect the amplifier circuitry against damage caused by prolonged exposure to high temperatures, a thermal protection circuit is activated if the amplifier reaches excessively high operating temperature. Once the thermal circuit is activated, the amplifier will shut down to cool off. The amplifier will automatically turn back on once it cools down to a safe operating temperature.

## ***Short Circuit Protection***

The circuit protects the amplifier from damage due to a short found in the speakers or wiring. If one of the speakers or its wiring comes in contact with ground, the amplifier will shut down. To resume normal operation, correct the problem and turn the head unit off, then back on. The amplifier will reset and play again.

## ***Built-in Crossover***

The "CSA" amplifier includes a built-in High Pass crossover @ 150Hz. The switchable crossover is set 150Hz to filter low frequencies

## ***Remote Turn-on***

Automatically turns amplifier on when connected to the head unit's remote output. The amplifier will turn on and off with the head unit to save current consumption.

## ***Remote Input Jack***

A remote input jack has been provided for connection with optional CSR-W Power and Volume Control. Allows independent remote volume control of amplifier. CSR-W is available in our Amplifier Kit, Tower Kit or Transom Kit.

## ***Adjustable Input Sensitivity***

Allows you to fine-tune the level matching between your source and the power amplifier.

## ***MOUNTING LOCATION***

Before you start the installation, it will be necessary to find a mounting location for the amplifier. Find a location in which the amplifier will receive adequate ventilation in order to dissipate the heat it develops during operation. Do not mount in the engine compartment.

Select the location in which you wish to mount the amplifier. Use caution when mounting amplifier, there are many wires, gas lines, vacuum lines, brake lines as well as a gas tank in the automobile. Make sure you know where they are when mounting the amplifier to avoid puncturing lines, shorting wires or drilling holes in the gas tank. Once you are ready, use a pencil to mark the mounting holes in the bottom panel. After you have marked the locations of the holes move amplifier out of the way and drill small starter holes to make the tapping screws easier to install. Use provided screws to tighten down the amplifier.

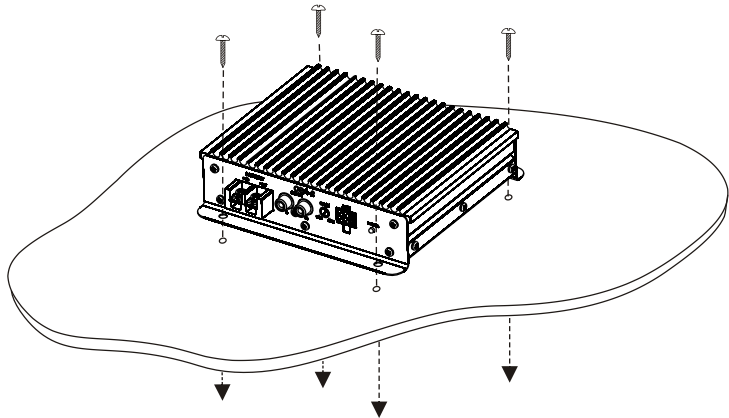



# POWER CONNECTIONS

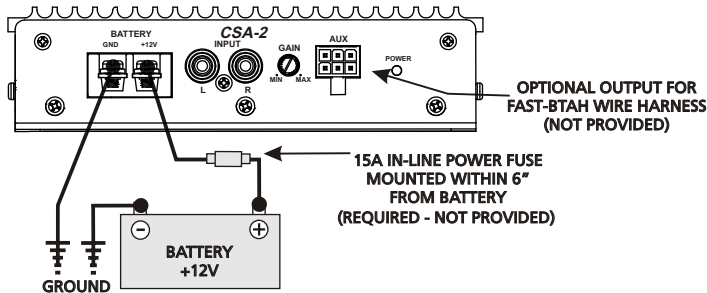

**IMPORTANT!** Before making any connections, disconnect the vehicles battery until the installation is completed to avoid possible damage to the electrical system.

## ***Connect the amplifier to the vehicles battery.***

Make your power connections using a 8 gauge power wire for your connections. Strip one end of the wire and attach a barrier spade. Located the terminal on the amplifier marked "+12V". Loosen screw terminal and connect the wire end with barrier spade and tighten. Use caution to make sure no stray wire strands come in contact with surrounding terminals causing short circuits. Run the wire to the vehicles battery. Insert a in-line 15 AMP fuse within 6" of the vehicle's battery to protect the electrical system and amplifier against short circuits and/or power surges. Connect to the battery's positive (+) terminal.

## ***Connect the ground terminal of the amplifier to the vehicles chassis ground.***

For the ground connection, use an 8 gauge wire (black) with a barrier spade attached and connect to the terminal marked "GND". Use a ground ring terminal on the remaining end of the wire and connect the wire to the vehicles chassis. Keep the length of the cable as short as possible, preferably less than 6".

**Connect the remote terminal of the amplifier to a switchable +12V source.**

This connection allows the amplifier to be turned on and off with the power control of the radio or CSS-3i. If the radio has a REMOTE output terminal, connect it to the amplifier's terminal marked "TURN-ON" (using a 16 gauge wire or heavier). Now when the radio or CSS-3i is turned on, the amplifier will automatically turn on.

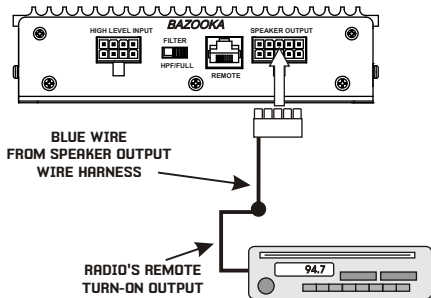

**REMOTE TURN ON WIRE  
SINGLE AMPLIFIER/SOURCE CONNECTION**

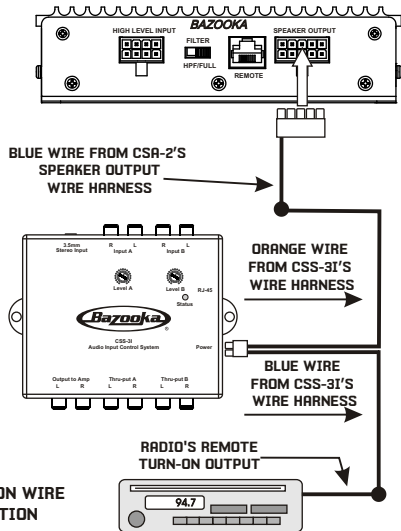

**REMOTE TURN ON WIRE  
CSS-3i CONNECTION**

# SIGNAL CONNECTIONS

*Connect the RCA output of the head unit or CSS-3 Audio Input Control Switch.*

The amplifier can be connected directly to your single input source such as CD Player, or with the optional CSS-3 Audio Input Switch you can connect to multiple input sources. The following diagrams show both configurations depending on your system configuration.

To make these connections, we recommend high quality RCA cables, which are available at your local Bazooka retailer. Run signal wires away from electrical wires to avoid possibility of induced noise from the vehicles electrical system (i.e. popping noises or engine noise).

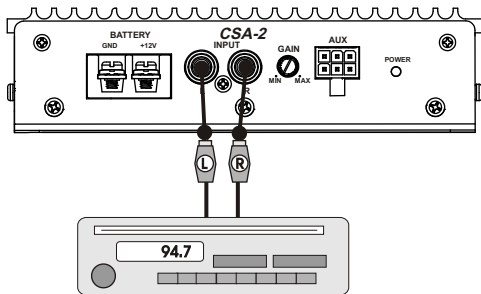

**SIGNAL CONNECTIONS USING SINGLE SOURCE INPUT**

# SIGNAL CONNECTIONS

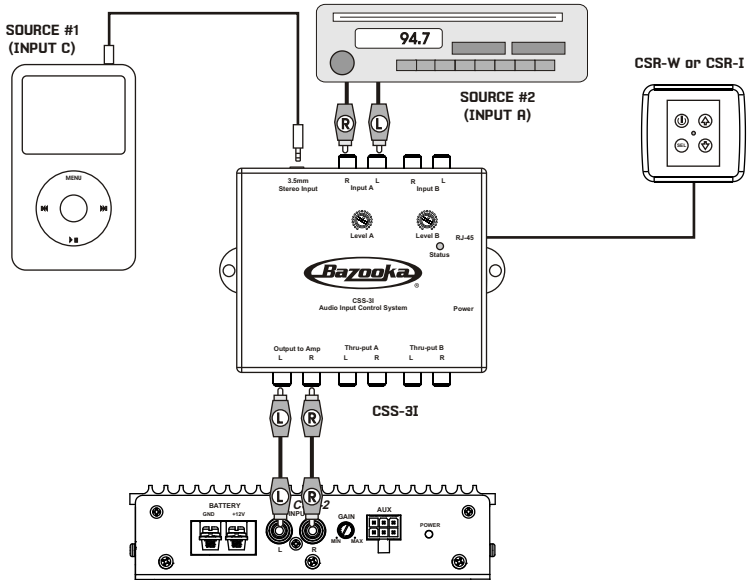

SIGNAL CONNECTIONS USING THE OPTIONAL CSS-3I  
WITH MULTIPLE SOURCE INPUT



## HIGH LEVEL CONNECTIONS (OPTIONAL)

High Level inputs have been included to connect the amplifier to a radio without low-level outputs (i.e. factory radio). This connection will allow you to connect directly to the speaker output of the radio with out the need of an external adapter.

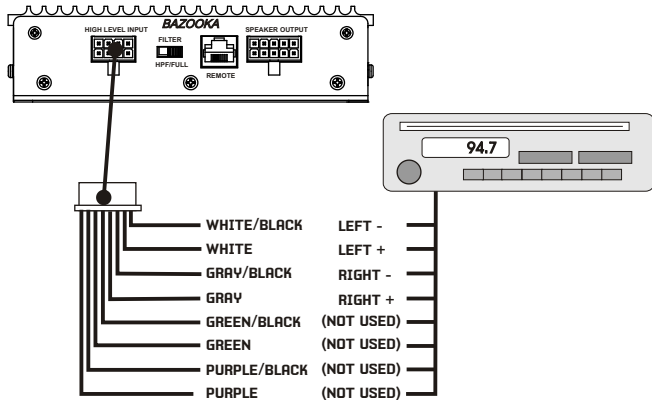

# SPEAKER CONNECTIONS

Make the speaker connections using speaker wire that is at least 16 gauge or heavier.

As with any audio component, proper phasing of the amplifier and speakers is essential for strong bass response. When connecting, make sure that positive (+) from the amplifier is connected to the positive (+) of the speaker, and the same for negative (-).

Eight wires from the harness are used to connect four speakers (4 ohm each). If you decide to use only two speakers, tape the unused wires so they do not come in contact with each other or chassis ground.

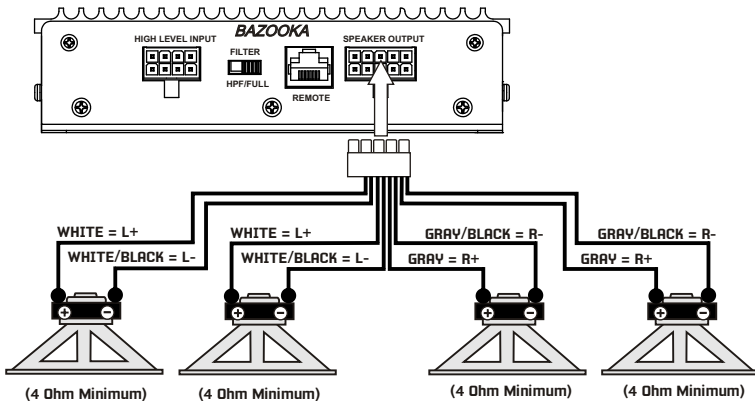

## REMOTE CONTROL / CSR-W (OPTIONAL)

Before connecting the remote, it will be necessary to find a mounting location that will be easy to access for adjustment. Once you select your mounting location, you will need to run the control wire from the remote to the amplifier. To avoid possibility of induced noise from the vehicle's electrical system (i.e. popping noises or engine noise), run the cable from the remote to the amplifier away from the vehicle's electrical wiring.

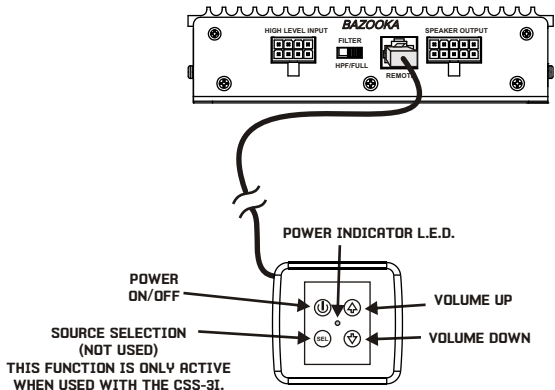

## ACTIVATING THE X-OVER

The "CSA-2" amplifier is equipped with a built-in 150Hz High Pass crossover network allowing you limit low frequencies to your speakers. To activate the crossover, slide the "FILTER" switch to the "HPF" position.

MOVE THE FILTER SWITCH  
TO THE "HPF" POSITION  
TO ACTIVATE THE X-OVER

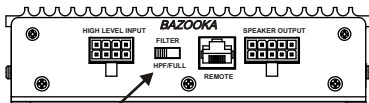

## FINE TUNE THE SYSTEM

Fine tune the amplifier's input sensitivity.



The gain sensitivity control for the "CSA" amplifier is located on the side panel. This gain control has been included to allow adjustment to properly match the output of the radio. This is one of the most misunderstood adjustments. By rotating the control in the clockwise direction, the amplifier's input will become more sensitive and the music will play louder.

This is not a volume control and you will not get more power out of the amplifier in the maximum position! It may seem to deliver more output, but actually the system is only playing louder faster as you turn the volume control on the radio. Ideally, to properly level match the system the goal is to achieve maximum output from the amplifier without distortion at about 3/4 of the volume control.

To determine if the amplifier's gain is set properly, turn the system on and slowly increase the volume control. You should be able to use about 3/4 volume before the system gets loud but not distorting. It is very important when making these adjustments that you do not over drive the speakers (at point of distortion) this will cause permanent damage to the speakers. If you are unable to achieve 3/4 volume before distortion you will need to adjust gain control (in this case you would reduce the gain). The gain controls should be adjusted very slowly. It may help to have another person to assist you by adjusting the gain controls while you listen for distortion.



# ***TROUBLE SHOOTING THE SYSTEM***

We have put together this trouble-shooting guide if you experience problems after installing the amplifier. Please keep in mind that the majority of problems incurred are caused by improper installation and not the equipment itself. In addition, there are many components in the system that could cause various signal problems such as inducted electrical noise and engine noise.

Before you can properly address the problem, you must first find the component that is causing the problem. This will take patience and a process of elimination.

LOOK FOR....	SOLUTION
<b>No Output</b>	
Blown fuse	Replace
Bad RCA Cable(s)	Replace
+12V at power terminal	Check connection
+12V at remote terminal	Check connection
Grounding point clean and tight	Check for ground w/meter
Head Unit's fader not in center position	Set to center position
<b>Low Output</b>	
Check level adjustments	Re-adjust
Bad RCA cable(s)	Replace
Improper level matching	Re-adjust
<b>Engine Noise</b>	
Grounding points are clean and tight	Check for ground w/meter
Ground all components at same point	Ground at same point
Try different grounding point	Change for better ground
Bad RCA cable(s)	Replace
Use High Quality shielded RCA cables	Rejects inducted noise
Low Vehicle charging system and/or battery	Fix and/or replace
<b>Music Stops Playing</b>	
Speaker short	Check speakers connection for short circuit
Speaker grounding out	Make sure speaker wires do not touch ground
Impedance too low	Check speaker impedance (Min 2 ohm Stereo)
Overheating	Check mounting location for Adequate air Circulation Speaker impedance too low

# ***SPECIFICATIONS***

CSA-2

Output Power @ 14.4 VDC :

4 ohm .....	30W x 2
2 ohm.....	50W x 2
Frequency Response (-3dB).....	20Hz-40KHz
S/N Ratio (A-weight).....	>75dB
THD (A-weight).....	0.3%
Low Input Level .....	100mV-2.2V
Hi Input Level .....	2.5V
Crossover Type .....	HP/FULL
Crossover Freq. (Fixed).....	150Hz
Jack for Remote Control.....	Yes
Battery Voltage Range .....	9.5VDC-16VDC
Fuse Required (Not Included) .....	25A x1

Due to continuing product improvement, specifications subject to change without notice.





## ***LIMITED WARRANTY***

Southern Audio Services, Inc., warrants all products to be free from defects in material and workmanship for a period of one (1) year from the date of purchase. In the event the product is not as warranted, SAS' sole obligation shall be to repair or replace the defective product at SAS' option: SAS limits its obligation under any implied warranties under state laws to a period not to exceed the limited warranty period. SAS and its authorized BAZOOKA® dealers specifically disclaim liability for any incidental or consequential damages. Some states do not allow limitations on how long an implied warranty lasts, and some states do not allow the exclusion or limitation of incidental or consequential damages, so the above limitation or exclusions may not apply to you. This warranty gives you specific legal rights, and you may have other rights, which vary from state to state.

**What is covered:** This warranty covers all defects in materials or workmanship (parts and labor) in the product.

**What is not covered:** This warranty does not cover the following:

1. Damages occurring during shipment of the product to SAS for repair (Claims must be presented to the carrier).
2. Damages caused by accident, abuse, negligence, misuse or improper Operation or installation.
3. Damages caused by an act of God, including without limitation, fire, flood Storm or other acts of nature.
4. Any product, which has a serial number, defaced, altered, modified, or removed.
5. Any product that has been altered or modified without SAS' consent.



### How to obtain warranty services:

1. You are responsible for delivery of the product to an authorized BAZOOKA® dealer or contact SAS at 1-800-THE-TUBE for a Return Authorization number. The Return Authorization number must be clearly written on the outside of the box. Freight must be prepaid to SAS. Warranty replacement parts will be returned freight prepaid. The entire enclosure may be returned for warranty service, but return will be freight collect.
2. You must provide proof of the date of purchase of the product. If proof of purchase is not provided, original date of manufacture will be used to determine warranty period.
3. You must package the product securely to avoid damage during shipment.
4. After acquiring a Return Authorization number, ship to the address below. Please complete this section and retain for your records.

Model(s) purchased \_\_\_\_\_

Serial number(s) \_\_\_\_\_

Date Purchased \_\_\_\_\_

Dealer's name \_\_\_\_\_







**If you have any questions contact the Bazooka Mobile Audio tech dept. at:**

**Phone: 225-272-7135 Fax: 225-272-9844**

**Email - [tech@bazooka.com](mailto:tech@bazooka.com) Website - [www.bazooka.com](http://www.bazooka.com)**