

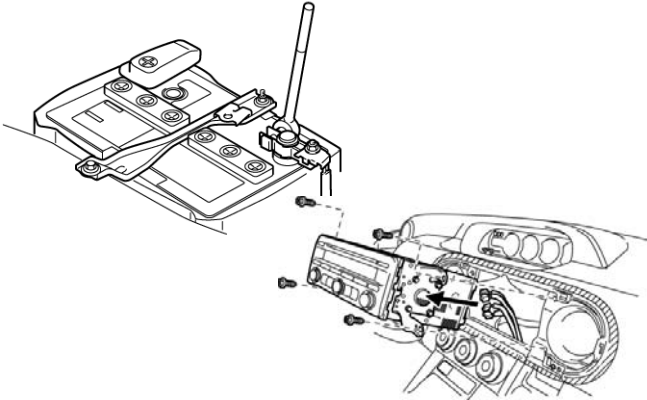

How to install the FAST-9999 with the FAST-BTAH



Disconnect negative battery clamp from battery. For easiest installation remove the radio and disconnect the harness from the back of the radio.

Red (+) 12V Power. Turns on when ignition/accessory is on.

Blue/White Turns on remote accessories (amplifiers, etc.). If there is no Remote Amplifier wire, you can often use the power antenna wire.

White (+) Left Front Speaker
White/Black (-) Left Front Speaker

Gray (+) Right Front Speaker
Gray/Black (-) Right Front Speaker

Connect the pin tap connectors to the corresponding wires of your radio harness. Consult your car or radio manufacturer's manual to get the correct color codes for your vehicle.

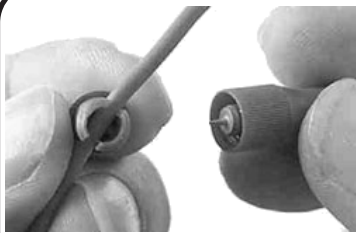

Remove the top cap. Place the wire that is going to be tapped. In the groove of the cap as far down as it will go.



Make sure not to cross thread the cap when screwing it back in place.

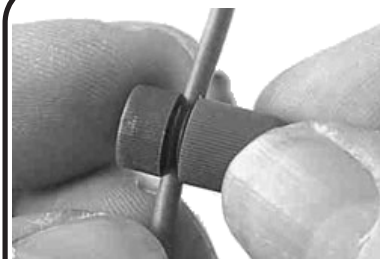

Continue to thread until the cap is tight and the wire is pierced.

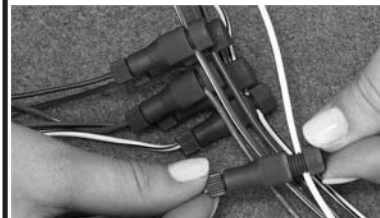

Make sure to attach all 6 of the FAST-9999 harness wires to your OEM harness.

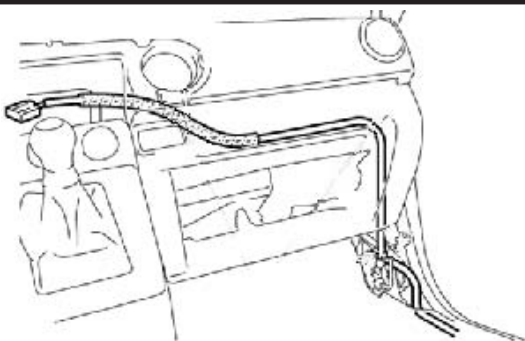

Make sure the end with the 6 pin Molex connectors is toward the radio. Run the BTAH harness behind radio, dash and along the edge of the vehicle until you get to the place you have decided to mount the tube.

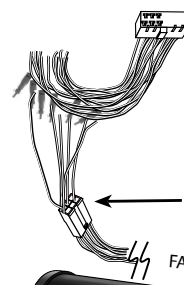

Plug the FAST-9999 harness into the FAST-BTAH. Mount grounding ring and plug the 14 pin connector into the BASS TUBE. For more information on placement and mounting, consult your amplified tube instruction manual.

